

M-12144 4

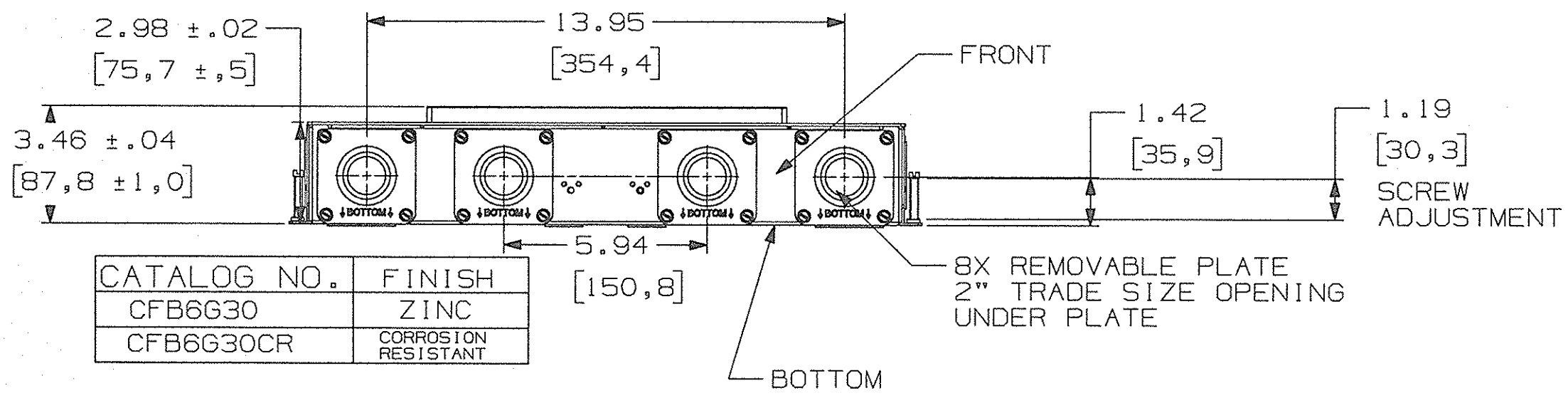
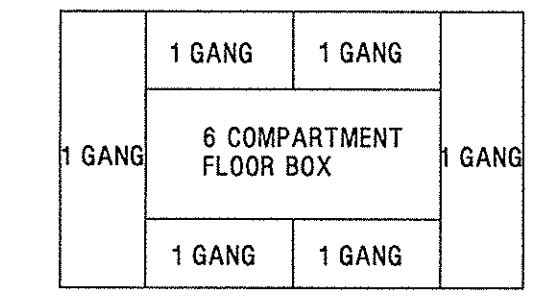
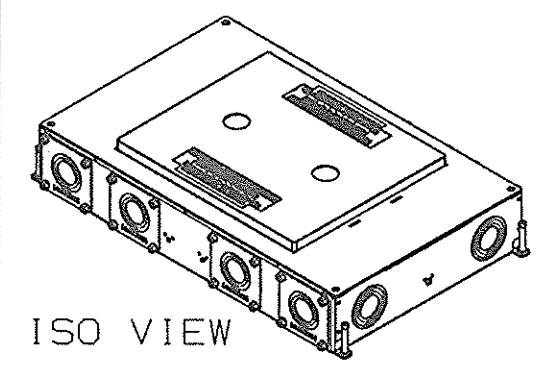
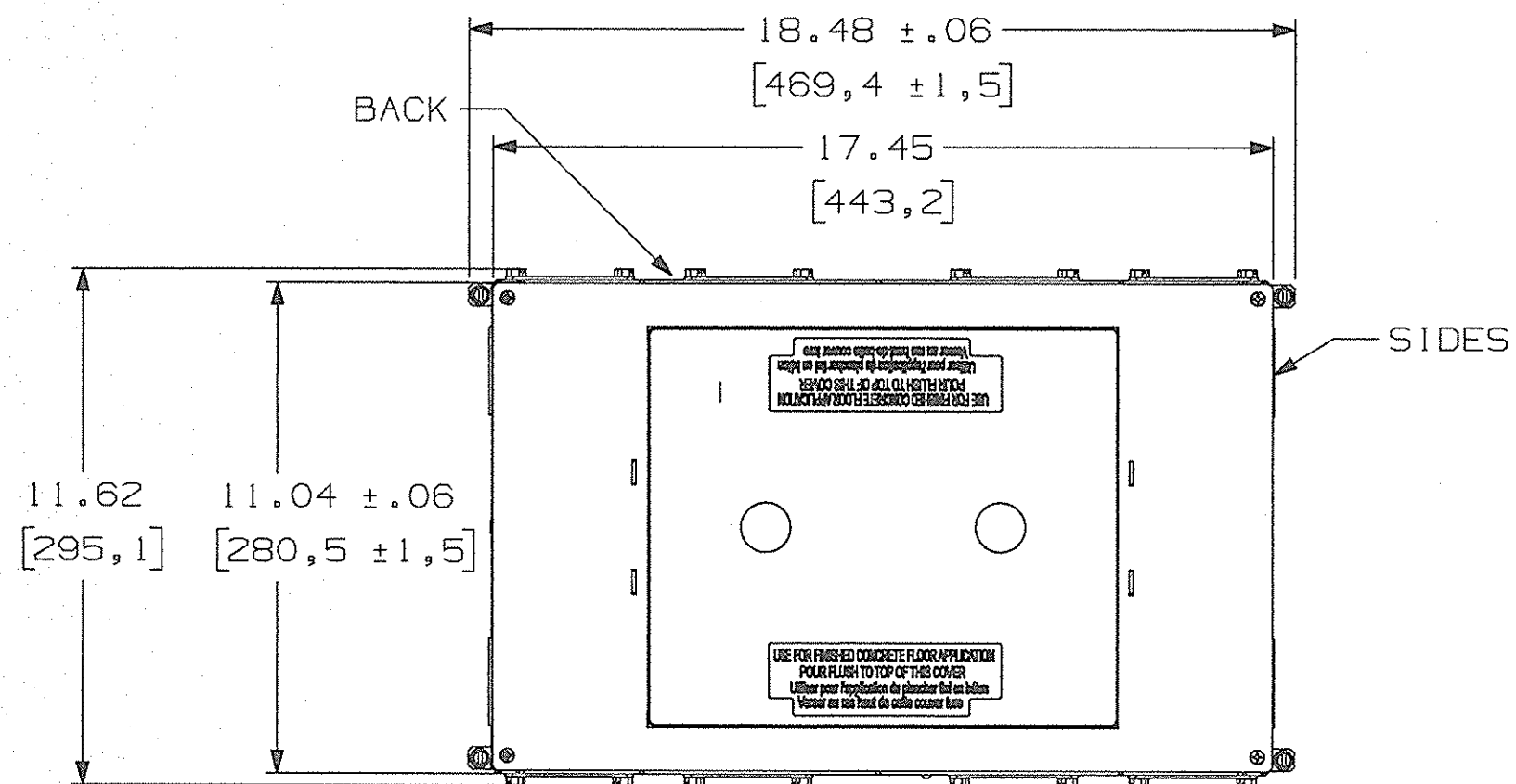

CATALOG NO.	FINISH
CFB6G30	ZINC
CFB6G30CR	CORROSION RESISTANT

K.O. TRADE SIZE	LOCATION	QTY
3/4, 1, 1-1/4	FRONT	4
3/4, 1, 1-1/4	BACK	4
3/4, 1, 1-1/4, 1-1/2	BOTTOM	4
3/4, 1, 1-1/4, 1-1/2	SIDES	4

NOTES: UNLESS OTHERWISE SPECIFIED:
 1. DIMENSIONS SHOWN ON THIS DRAWING ARE NOMINAL VALUES FOR GENERAL USE ONLY. ACTUAL PART TOLERANCES MUST BE OBTAINED FROM HUBBELL ENGINEERING.
 2. PRODUCT IS cULus LISTED.
 3. DIMENSIONS ARE IN INCHES [mm].

LIST OF PARTS

DESCRIPTION	MATERIAL	FINISH
FLOOR BOX	STEEL	PRE-GALVANIZED
WIRE BARRIER	STEEL	PRE-GALVANIZED
TOP MOUNTING ASSY.	STEEL	ZINC PLATED
#8-32 FLAT HEAD SCREW	CRS	ZINC PLATED
#6-32 BINDING SCREW	CRS	ZINC PLATED
#12 AWG GRD. WIRE & SCR ASSY.	COPPER	
PRE-POUR LEVELING SCREW	STEEL WIRE	ZINC PLATED
METAL CONCRETE COVER	STEEL	PRE-GALVANIZED
DIVIDER	PET	
PLASTIC CONCRETE COVER	POLYPROPYLENE	
4 GANG DIVIDER	PET	

SYM	REVISIONS	APP	DATE
4	09/16/14 UPDATED KO TABLE FOR FLOOR BOX PER DCN 20784 CAC	CAC	09/16/14
3	06/10/14 UPDATED MODELS ADDED 6 COMPARTMENT VIEW PER DCN 20574 CAC		06/10/14
2	10/07/13 UPDATED BOX & KO'S PER DCN 20073 CAC		10/07/13
1	1/19/12 RELEASE FOR PRODUCTION PER DCN 18427 MJM TLS	TLS	1/19/12

THE DESIGN AND DIMENSIONS OF THE PRODUCT SHOWN ON THIS DRAWING ARE SUBJECT TO CHANGE WITHOUT NOTICE

TITLE
6 GANG CONCRETE BOX ASSY.

TOLERANCES UNLESS OTHERWISE SPECIFIED .XX = ±.01 .XXX = ±.005 ANGLES = ±2°	WIRING DEVICE-KELLEMS HUBBELL INCORPORATED SHELTON, CT	
	DR. BY MJM	APP. BY
	TR. BY	SCALE 1/4
	CHK. BY	DATE 1/11/12

DIMENSION SHEET FOR CAT. NO. M-12144
 SEE FIELD OF DRAWING
 REPAIRABLE NON-REPAIRABLE
 B
 M-12144
 4